

# SMD Power Inductor

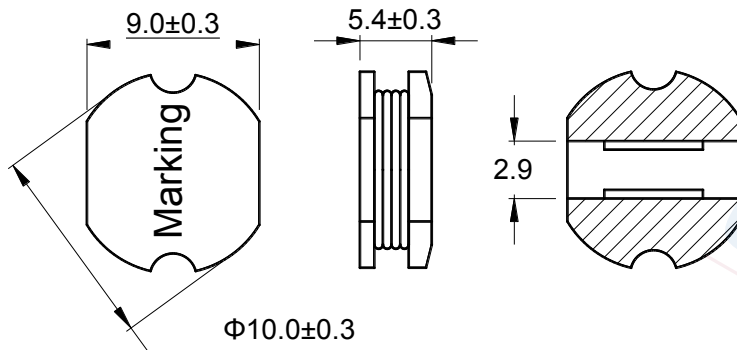

## 1 Appearance and dimensions (mm)

外形尺寸



## 2 Reference land pattern (mm)

参考基板尺寸

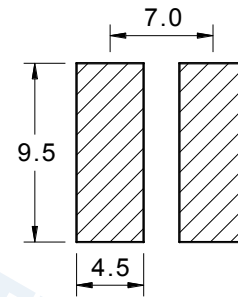

## 3 Electrical characteristics 电气特性

Part No. 型号	Inductance (μH) 电感值 ※1	D.C.R. (mΩ) 直流电阻		Saturation current (A) 饱和电流 ※2		Temperature rise current (A) 温升电流 ※3
		Typical	Max	Typical	Max	Typical
ECD105-1R2M	1.20 ±20%	5.91	7.09	12.0	9.60	8.81
ECD105-1R8M	1.80 ±20%	7.22	8.66	10.2	8.16	8.26
ECD105-3R3M	3.30 ±20%	10.3	12.3	7.90	6.32	6.65
ECD105-4R7M	4.70 ±20%	12.0	14.3	7.00	5.60	6.46
ECD105-6R8M	6.80 ±20%	15.4	18.4	5.80	4.64	5.72
ECD105-8R2M	8.20 ±20%	19.3	23.1	5.10	4.08	5.17
ECD105-100K	10.0 ±10%	21.0	25.1	4.50	3.60	4.89
ECD105-120K	12.0 ±10%	25.2	30.2	4.20	3.36	4.47
ECD105-150K	15.0 ±10%	29.5	35.4	3.80	3.04	4.11
ECD105-180K	18.0 ±10%	36.4	43.7	3.50	2.80	3.73
ECD105-220K	22.0 ±10%	45.6	54.7	3.20	2.56	3.31
ECD105-270K	27.0 ±10%	54.1	64.9	2.85	2.28	3.06
ECD105-330K	33.0 ±10%	67.0	80.4	2.60	2.08	2.72
ECD105-390K	39.0 ±10%	80.7	96.8	2.40	1.92	2.49
ECD105-470K	47.0 ±10%	92.7	111	2.20	1.76	2.32
ECD105-560K	56.0 ±10%	109	131	2.00	1.60	2.17
ECD105-680K	68.0 ±10%	129	155	1.80	1.44	1.96
ECD105-820K	82.0 ±10%	161	193	1.60	1.28	1.76
ECD105-101K	100 ±10%	190	228	1.45	1.16	1.62
ECD105-121K	120 ±10%	234	280	1.35	1.08	1.44
ECD105-151K	150 ±10%	265	318	1.23	0.98	1.37
ECD105-181K	180 ±10%	341	410	1.13	0.90	1.23
ECD105-221K	220 ±10%	400	480	1.02	0.82	1.12
ECD105-271K	270 ±10%	500	600	0.92	0.74	1.00
ECD105-331K	330 ±10%	627	752	0.82	0.66	0.88
ECD105-391K	390 ±10%	706	847	0.76	0.61	0.83
ECD105-471K	470 ±10%	850	1,020	0.70	0.56	0.76
ECD105-561K	560 ±10%	1,000	1,200	0.63	0.50	0.70
ECD105-681K	680 ±10%	1,204	1,445	0.58	0.46	0.65
ECD105-821K	820 ±10%	1,430	1,716	0.51	0.41	0.58
ECD105-102K	1,000 ±10%	1,842	2,210	0.47	0.38	0.52
ECD105-222K	2,200 ±10%	3,850	4,620	0.35	0.28	0.36
ECD105-472K	4,700 ±10%	8,640	1,0300	0.24	0.20	0.24

All data is tested based on 25°C ambient temperature. 所有测试数据基于环境温度25°C条件下测试。

※1. Inductance measure condition at 100kHz, 0.1V. 电感测试条件为100kHz, 0.1V。

※2. Saturation current the actual value of DC current when the inductance decrease 20% of its initial value.  
饱和电流: 电感值下降其初始值的20%时所加载的实际直流电流值。

※3. Temperature rise current the actual value of DC current when the temperature rise is ΔT40 (Ta=25).  
温升电流: 使产品温度上升到ΔT40°C时所加载的实际直流电流值(Ta=25°C)



Balun Transformer | Coupler | Divider | Inductor | Choke | Bead Air Coil | LAN Transformer